

VANDE HEY RALEIGH STANDARD WEIGHT CONCRETE HIGH BARREL SPANISH TILE

TECHNICAL DATA

<u>DIMENSIONS</u>	<u>TILE PER SQUARE WITH 3" HEADLAP</u>	<u>EXPOSURE PERTILE</u>	<u>APPROX POUNDS PERSQ</u>	<u>APPROX KGS PER SQMETER</u>	<u>APPROX SQS PER PALLET</u>
17 1/4" X 13"	86	14" X 12"	1000	47.6	2.65

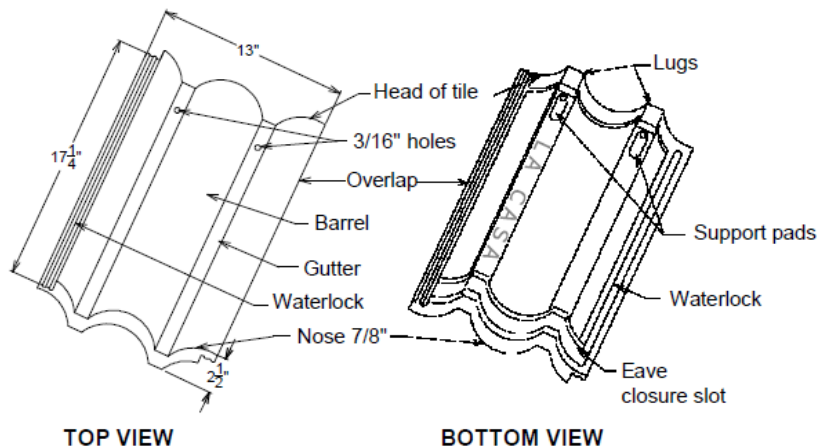

American Test Lab of South Florida attests that the sketch and dimensions provided herein is representative of the tiles tested by ATLSF as reported in Reports: RT0618.02-18 & RT0803.02-18.

Stephen W. Warter, P.E.
 Reg. State of Florida # 54395
 American Test Lab of South Florida

